

# IRIS STA C1D2

## Installation instructions

This product must be installed by a qualified electrician, please read this instruction before installation.

### To Dear clients:

Thanks for purchasing our products! In order to ensure that you fully understand to use this product safely and properly, please read the instructions carefully. Meanwhile, please keep this manual carefully for reference in the future.

### Remind:

1. For installation or maintenance, please cut off power supply and Don't open the enclosure while in the explosive atmosphere. Before turn it on, must confirm the light source and electrical installation is right connected.
2. No matter what circumstances, LED Luminaires can't be covered by thermal insulation material, or similar materials.
3. When an exception occurs, please quickly cut off the power and contact the distributor.
4. The product is suitable for outdoor use, under using or just cut off the power, please don't touch the light.
5. Any maintenance should be performed by trained professionals only.

## 1. General Description

This fixture is LED Luminaires; Rating is 100-277VAC or 200-480VAC; 50/60Hz. Maximum input power is 300W

### Comply with

UL1598, UL1598A, UL8750, UL844

### 1.1 Mark of flameproof type and location:

The label shall be include below protection mark and ambient temperature.

Protection Method(s)	Temperature Classification	Ambient Temp.
Flame-proof	T3	-40°C to +55°C
Class I Div.2 groups A, B, C,D; Class II Div.1 groups E, F, G; Class II Div.2 groups F, G; Class III		

### ● Electrostatic warning:

POTENTIAL ELECTROSTATIC CHARGING HAZARD - SEE INSTRUCTIONS!:

Clean the luminaires by damp cloth

### WARNING:

- KEEP TIGHTLY CLOSED WHEN IN OPERATION.
- DO NOT OPEN WHEN AN EXPLOSIVE ATMOSPHERE IS PRESENT!
- POTENTIAL ELECTROSTAIC CHARGING HAZARD-SEE INSTRUCTIONS!

### CAUTION:

- Min 105°C power supply cable shall be provide.
- Cable gland certified separately shall be installed.

## 2. Instructions for safety addressing

### ● On-site assembling

This instruction is specialized installation information for the user, based on the fixture is used for hazardous location, the installer shall be qualified electrician. The entry threads are 3/4" NPT, please double the check the mark on the entry and select the pipe thread .

### ● Installation and erection

The power wire need to install in the explosion proof power pipe system or metal conduit, water proof connector need to apply in cable connection.

### ● Adjustment and parameter setting

The minimum height of installation is 2 meters for this luminaires, it's for heating dissipation, please don't try to install less than the height.

### ● Putting into service - of the equipment / of the whole installation

Based one above conditions, the luminaires can contact into the 100-277/200-480VAC 50/60Hz power system, turn on the power to test the single fixture is work, and then start to mass install other luminaires.

### ● Use and setting-up

All fixtures need to test the wiring is correct and the installation is safe before using, it will avoid the risk of electrical damage, installation safety problem, however these jobs must be carried by a qualified electrician.

**Rated power:** 100~277VAC or 200~480VAC; 50/60Hz.; **Ambient Temp.:** -40°C~ +55°C; **Temperature class:** T3; **Max surface Temp:** T135°C; **Gas:** Class I Div.2 groups A, B, C, D; **Dust:** Class II Div.1 E, F, G; **Fibre:** Class III Div.1 & 2

### ● Maintenance

We recommend the user to clean the luminaires every 3 ~ 6 months by damp cloth if it's dirty. Please ask the qualified electrician to check if the fixture flicker or buzz.

### ● Assembling and dismantling

For a convenient packing, the accessories need to pack independently, so the installer need to read the instruction carefully before assembling accessories. Please contact the manufacture if there are some confusions during the installation.

It's very important that turn off the power before removing the fixtures, and the installer need to have a qualified electrician, remember that turn off the power at least 5 minutes to operate the remove.

### ● Repair

To reduce the risk of ignition of hazardous atmospheres, disconnect the luminaire from the supply circuit opening. Keep tightly closed when in operation, connect the grounding finally. Don't try to repair a damage lamp if someone without an electrical license. When luminaire damaged, please don't try to repair the fixture without manufacture's guide. The manufacture will repair damage fixtures if they are in the warranty.

### ● Where applicable and special remind

The suitable application location is for gas zone 2, dust zone 21 & zone 22; the gas group is IIC and dust group is

## STA Street light installation instructions

IIIC; gas EPL will be Gc, dust EPL will be Db. Please don't use a bend appearance fixture if you found this case.

- **Training instructions for a safe use**

The wiring diagram refer to below installation detailed instruction. Roughly, black wire contact to live wire, white wire to null wire, green and yellow wire to grounding. The connectors shall be in the junction box and the cable should be in the metal pipe or conduit.

- **Packing list**

That packing includes a equipment list as following

Items	QTY	Remark
Fixture	1	
Mounting accessory	1	
Installation instruction	1	

- **Store temp.:** -40~+90℃

## 3. Instructions for installation

### Critical Features

1. **Spacing** - In primary circuits, 6.4 mm minimum spacing are maintained through air and 3.2 mm over surfaces of insulating material between current-carrying parts of opposite polarity and between such current-carrying parts and dead-metal parts or low voltage isolated circuits.
2. **Accessibility of Live Parts** - All uninsulated live parts in primary circuitry should housed within a metal enclosure constructed with no openings.
3. **Grounding** - Internal grounding wire should connected to PE, external grounding wire should connected to the equipment protective ground wire, both internal and external grounding wire section area is not less than 4mm<sup>2</sup>.
4. **Gable Gland** - An Ex certified cable gland need to assemble in entry for protection. Its marking shall be Ex db II C Gb, Ex tb III C Db IP66/IP68. The cable diameter is 8-11 mm, at least 250mm non-circular and sheath shall be keep for cable gland rubber holder. Please engaged at least 6 pcs threads by a tightening torque 130~180 N.m.
5. The cement joints are formed by epoxy glue and sealing rings are made of silicon rubber. The Ex safety of this product is depend on these components and materials. They may be damaged by aggressive environment. So the chemical compatibility of material and surrounding environment needs to be considered before use. If this product to be stored/installed in an environment that may damage these components, please contact with us.

### Installation notice

- The installer need to refer to **ANSI C136** standard.
- Internal and external grounding wire, including Single-conductor or Multiple-conductor, should be typed with steel cable lug first, then connected to the grounding connector .tighten the screw and make sure screw torque not less than 2.2Nm.
- When LED luminaires are installed in explosive gas atmosphere, cable gland or blanking plug, complying with EN60079-0 and EN60079-1 with type of protection Ex db IIB+H2 Gb and degree of protection IP66, shall be adopted.



## STA Street light installation instructions

- Maximum service temperature of cable for field wiring shall be no less than 105°C, when the LED luminaires are used for -40~+55°C.
- **Gasket frequency of replacement:** It's no need to replace the power enclosure gasket in the first 5 years, the installer can replace the power gasket when you are in the sixth year's maintenance. The replacement is to be conducted by contacting with manufacturer using the sealing ring and sealing glue provided by the manufacturer. Clean the seal groove and then apply the sealing glue to it. Put seal ring into the groove and fasten for 20 minutes. Please do not open and replace light source enclosure gasket and the joint between light source enclosure and power enclosure. (Gasket installation- Match the gasket to the gap and close the enclosure. Please don't touch the lamp when just cut off power)
- Forbid to disassemble other components except power enclosure cover! If opened by misoperation please contact the distributor.
- **Entry:** 3/4 NPT, Minimum number of engaged threads 6 pcs.

**Section of cable:** All power supply wires minimum is 18AWG, and external ground wire minimum section is 4 mm<sup>2</sup>.

- **Type of cable gland:** 3/4 NPT, suitable for 8~11mm diameter cable.

## Operation instructions

### 1. Slip mount

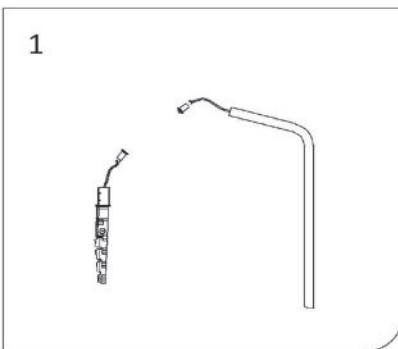

- ① Connect a water proof connector AC cable and lamp cable.

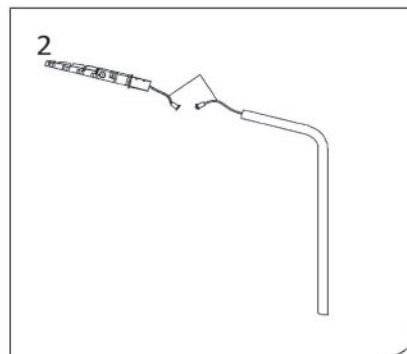

- ② Connect the water proof connector.



- ③ Install the slip mount to the lamppost.

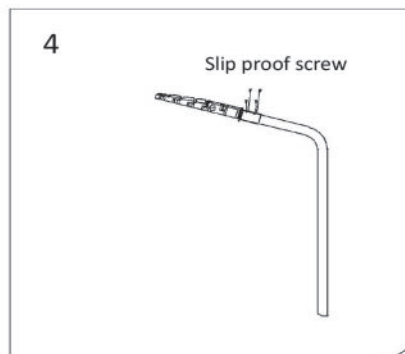

- ④ Tighten the slip proof screws.

# STA Street light installation instructions

## 2. Trunnion mount

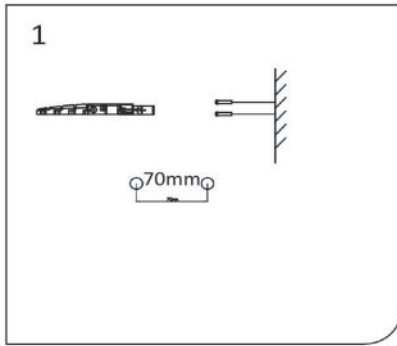

① Drill two 8mm holes for expanded screws.

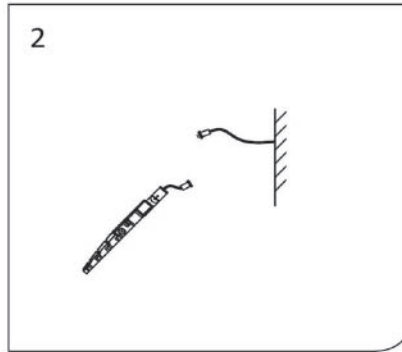

② Connect the water proof connector.

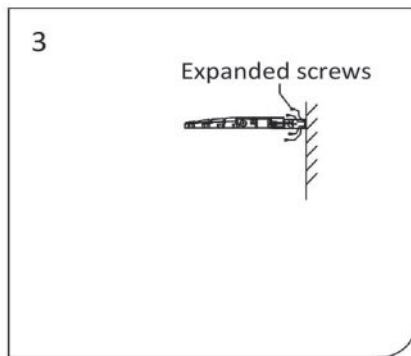

③ Tighten the expanded screws.

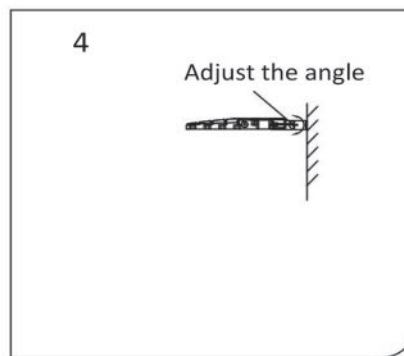

④ Adjust the bracket for suitable angle.

## 3. Arm mount

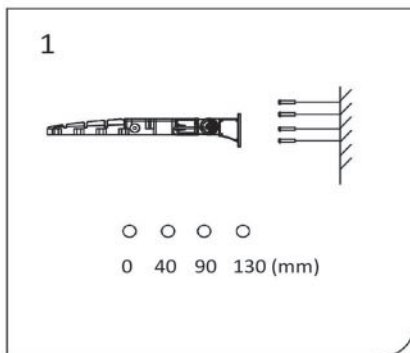

① Drill 4× holes as fig. 1, the distance as per above dimensions.

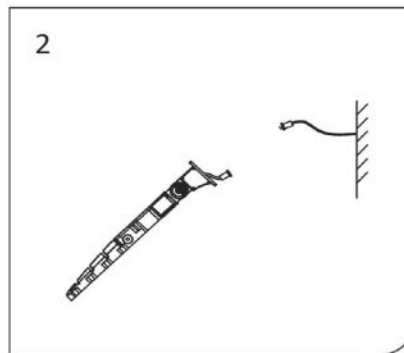

② Connect the water proof connector.

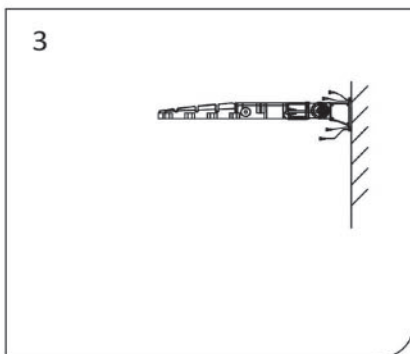

③ Tighten the 4× screws for fixing arm.

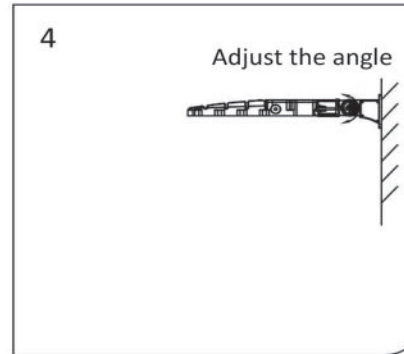

④ Adjust the arm for suitable angle.