

Product Description

The Focus Class 1, Division 2 explosion proof hazardous location luminaire is available with a clear tempered glass lens. Typical lighting applications include industrial facilities, oil, gas, painting facilities, manufacturing, and auto service facilities. From benchmarking a minimum 104 degree F ambient during thermal testing, to custom designed LED arrays, each aspect was considered to ensure many years of service.

> Quick Ship - In Stock, Ready to Ship

Project:		Type:
Location:		
Prepared By:		Date:
Comments:		

Performance Summary

- Samsung 561B LEDs with high efficacy >115 Lm/W
- Buy American Act and ARRA compliant
- Quick Ship - In stock and ships from six locations for quick delivery
- USA assembled product with quick warranty support
- Listed for hazardous locations per UL844 for Class 1, Div 2, Groups A, B, C, D
- Standard design with modern components, excellent choice for retrofitting
- Patented heat dissipation design for optimum efficiency - T4 temperature rating
- National listing lab tested to IES standards
- High lumen maintenance exceeds DOE requirements
- Aluminum LED boards with copper tracings for best thermal management
- LED array manufactured using a state-of-the-art SMT machine
- Clear tempered glass lens
- A360 extruded ingot die-cast housing
- DuPont textured architectural powdercoat gray finish
- Chromate conversion coating for long lasting appearance
- Mounts directly to a wall, conduit pendant, ceiling mount surface
- Stamped steel adjustable yoke and stanchions are available
- Cord rated for 6 #12 AWG 90°C for through wiring
- Rust resistant stainless steel hardware with durable nickel-plating
- High CRI - RA>80 enhances original colors
- 0-10V dimmable driver with integrated 6kV surge protection
- Fast turn on with no warm up or cold start issues
- Contains no mercury, lead, infrared or UV radiation and cool to the touch
- Operating temperature: -25 to 50 degrees celsius
- Samsung chip platform with completed 6,000 hour LM-80 test
- 329,000 hour LED life @ L70 tested at 25 degrees celsius
- Certifications: CE, RoHS, ETL, cETL - IP66 indoor or outdoor rated
- 10 year limited warranty

FOCUS C1D2 LV3

Class 1, Division 2 Hazardous with Multiple Mounting Options
LED Dimmable Luminaire

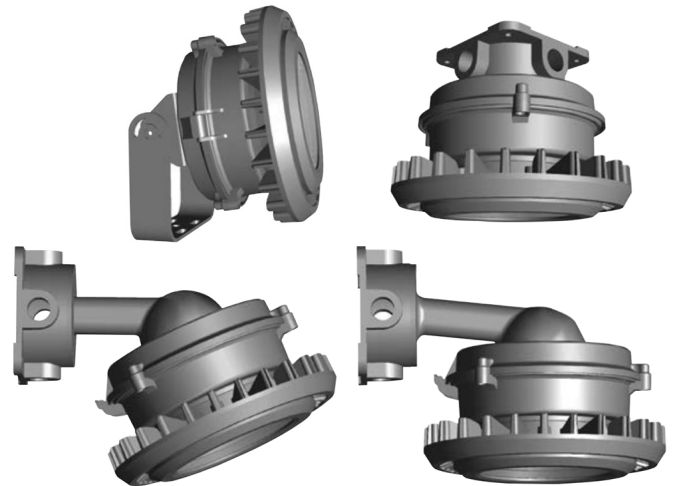

Models:

- WDHL15Q: 57W - 8957Lm - 175mA - Round Housing

Ordering Information:					Part Number:	Ordering Example: WDHL15Q-50-S5C-V27-CF-GR-DM		
Family	CCT	Optic	Voltage	Lens	Finish	Dimming	Accessories*	
WDHL15Q	40 - 4000K 50 - 5000K	S5C - 110°H x 110°V, NEMA 7H x 7V	V27 - 120-277V	CF - Clear Glass	GR - Gray	DM - 0-10V Dim	SP - 20kA Surge Protection 120-277VAC PM - Pendant Mount (Conduit by others) CM - Ceiling Mount Wiring Box WA25 - 25 Degree Wall Mount Arm WA90 - 90 Degree Wall Mount Arm ST25 - 25 Degree Stanchion ST90 - 90 Degree Stanchion YK - Adjustable Yoke Mount	



Vivid Leds, Inc.
PO BOX 9
Sellersburg, IN 47172
800-974-3570
www.vividleds.us

Dimensions, specifications, and product pictures are subject to change without notice.

F14

Dimensions:

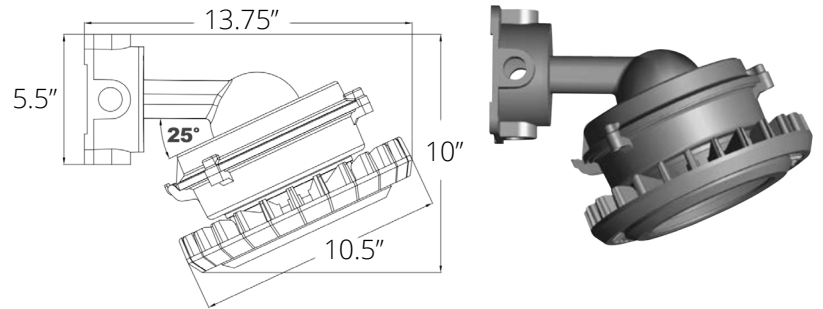

VDHLP15Q-WA25

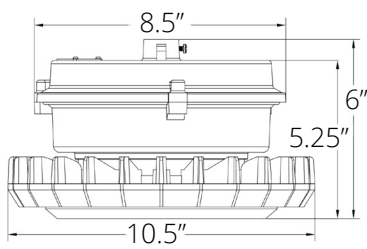

VDHLP15Q-PM

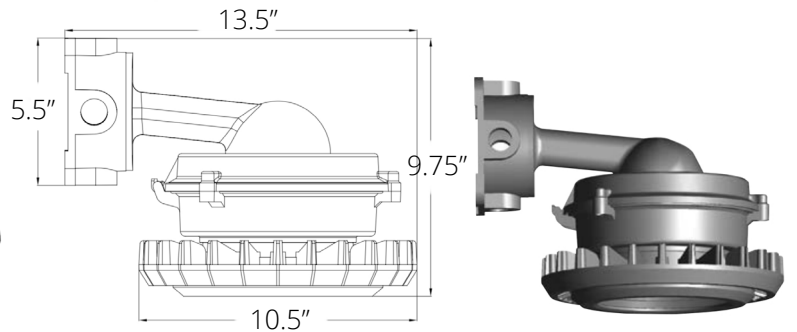

VDHLP15Q-WA90

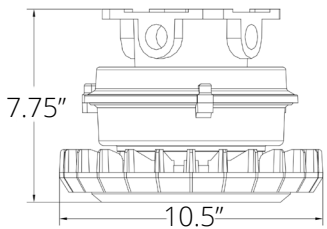

VDHLP15Q-CM

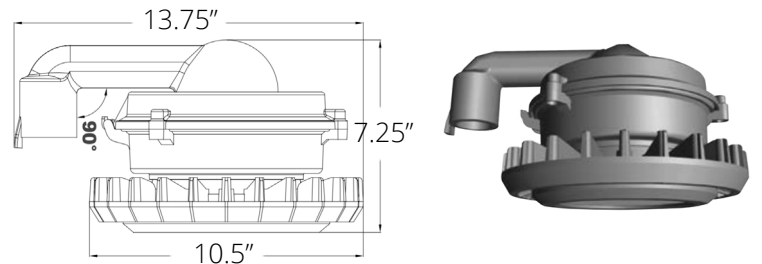

VDHLP15Q-ST90

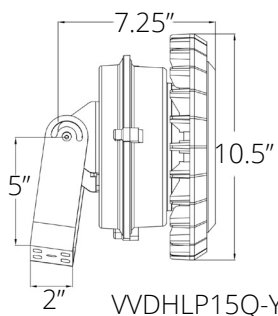

VDHLP15Q-YK

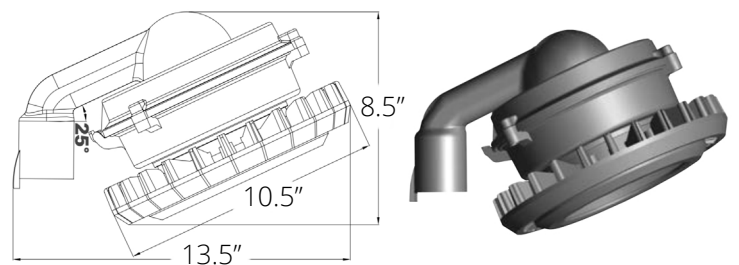

VDHLP15Q-ST25



Vivid Leds, Inc.
PO BOX 9
Sellersburg, IN 47172
800-974-3570
www.vividleds.us

Dimensions, specifications, and product pictures are subject to change without notice.

The product on this page is a manufactured to order, non-stocking item. This product cannot be returned for refund or credit.