

## Product Description

This LED high bay and aisle lighter is available with a choice of four lenses designed to replace HID lighting systems up to 1000w MH. Typical high bay lighting applications include warehouses, manufacturing facilities, gymnasiums, indoor sports facilities, and retail and big box store lighting. Suitable for 16 to 30 foot mounting heights based on light level and uniformity requirements.

> Quick Ship - In Stock, Ready to Ship

Project:		Type:
Location:		
Prepared By:		Date:
Comments:		

## Performance Summary

- Samsung LEDs with high efficacy >110 Lm/W
- Buy American Act and ARRA compliant
- Quick Ship - In stock and ships from six locations for quick delivery
- USA assembled product with quick warranty support
- Standard design with modern components, excellent choice for retrofitting
- National listing lab tested to IES standards with Type V optic
- High lumen maintenance exceeds DOE requirements
- Photometric optic built over each LED for enhanced light distribution
- Solid State with high-shock and vibration resistance
- Aluminum LED boards with copper tracings for best thermal management
- LED array manufactured using a state-of-the-art SMT machine
- Clear flat glass, acrylic conical, acrylic drop or polycarbonate drop lens available
- A360 extruded ingot die-cast housing and external heat sinks
- DuPont textured architectural powdercoat finish
- Chromate conversion coating for long lasting appearance
- Mounts with included 1" malleable hook and includes 4" aluminum stem
- Rust resistant stainless steel hardware with durable nickel-plating
- Fin heatsinks for best heat dissipation and long life
- High CRI - RA>80 enhances original colors
- 0-10V dimmable driver with surge protection
- Fast turn on with no warm up or cold start issues
- Contains no mercury, lead, infrared or UV radiation and cool to the touch
- Operating temperature: -40 to 50 degrees celsius
- Samsung chip platform with completed 6,000 hour LM-80 test
- 302,000 hour LED life @ L70 tested at 25 degrees celsius
- Certifications: CE, RoHS, CSA - IP54 indoor rated
- 10 year limited warranty

## INDUSTRY SQ

Rugged Housing with 1" Malleable Hook  
Dimmable LED COB Luminaire

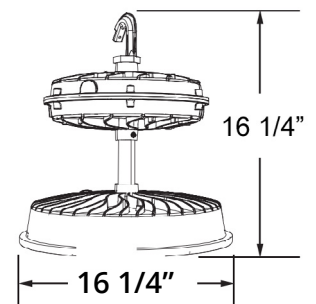

## Models:

- WDHB44C3: 170W - 19019 Lm - 16.25" Diameter

Ordering Information:				Part Number:		
*Adder Applies				Ordering Example: WDHB44C3-50-NL-V27-WT-ND		
Family	CCT	Optic	Voltage	Finish	Dimming	Accessories*
VDHB44Q3	40 - 4000K 50 - 5000K	NL - No Lens CG - Clear Flat Glass Lens* CL - Acrylic Conical Lens* DL - Acrylic Drop Lens* PC - Polycarbonate Drop Lens*	V27 - 120-277V V48 = 347-480V	WT - White CS - Custom*	ND - Non Dim DM - 0-10V Dim	SF - Single Fuse DF - Double Fuse SP - 20kA Surge Protection 120-277VAC M3 - Microwave Motion Sensor Minimum 20' Mounting Height WG - Wire Guard for use with Flat Glass Lenses CP1 - 6 Foot White Cord, 300VAC, 3 Wire, Leads CP2 - 6 Foot White Cord, 3 Wire, L5-15P Twist-Lock Plug, 120V CP3 - 6 Foot White Cord, 3 Wire, L7-15P Twist-Lock Plug, 277V CP4 - 6 Foot Black Cord, Type STW, 600VAC, 3 Wire, Leads SC - 3 Foot Safety Cable



Vivid Leds, Inc.  
PO BOX 9  
Sellersburg, IN 47172  
800-974-3570  
www.vividleds.us

Dimensions, specifications, and product pictures are subject to change without notice.

E6