

Product Description

The Axis Trail Series provides provides full cutoff lighting for outdoor path, walkways and landscape areas using wide spread optics designed to replace outdated Halogen and Compact Fluorescent lighting systems. These fixtures are ideal for retail centers, restaurants, hotels, schools and universities, public transit and airports, office buildings and medical facilities.

> Quick Ship - In Stock, Ready to Ship

Project:		Type:
Location:		
Prepared By:		Date:
Comments:		

Performance Summary

- Samsung LH351Z LEDs with high efficacy >110 Lm/W
- Buy American Act and ARRA compliant
- Quick Ship - In stock and ships from six locations for quick delivery
- USA assembled product with quick warranty support
- Patented heat dissipation design for optimum efficiency
- National listing lab tested to Type V IES standards
- High lumen maintenance exceeds DOE requirements
- Photometric optic built over each LED for enhanced light distribution
- Solid State with high-shock and vibration resistance
- LED array manufactured using a state-of-the-art SMT machine
- Clear or diffused polycarbonate array lens for reduced hot spots
- Robotically applied gaskets for consistent sealing
- Aluminum LED boards with copper tracings for best thermal management
- Individual optics robotically applied and sonically welded for precise light control
- A360 extruded ingot die-cast housing with heat sinking creates a sealed environment
- DuPont textured architectural powdercoat finish
- Chromate conversion coating for long lasting appearance
- Custom housing colors available upon request
- Threaded 3/4" aluminum 20" stanchion included
- Includes 3/4" to 1/2" threaded adapter
- Rust resistant stainless steel hardware with durable nickel-plating
- High CRI - RA>80 enhances original colors
- 1-10V dimmable driver with surge protection option
- Fast turn on with no warm up or cold start issues
- Contains no mercury, lead, infrared or UV radiation and cool to the touch
- Operating temperature: -40 to 50 degrees celsius
- Samsung TZ chip platform with completed 6,000 hour LM-80 test
- 187,000 hour LED life @ L70 tested at 25 degrees celsius
- Certifications: CE, RoHS, CSA - IP66 outdoor rated
- 10 year limited warranty

AXIS TRAIL

Walkway, Trail, or Path Light
LED Dimmable Luminaire

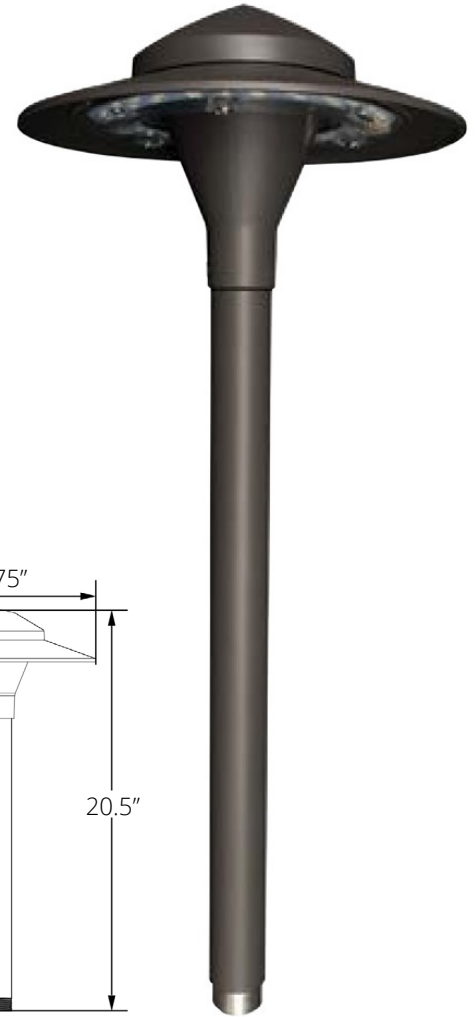

Models:

- WDDNP20: 14W - 1543 Lm - 125 mA

Ordering Information:				Part Number:	
*Adder Applies		**Adder Applies. Extended Lead Time May Apply.		Ordering Example: WDDNP20-40C-12-BZ-ND	
Family	Optic	Voltage	Finish	Dimming	Accessories*
WDDNP20	40C - 4000K - Clear Lens 40D - 4000K - Diffused Lens	V27 - 120-277V 12 - 12VDC	BZ - Bronze CS - Custom**	ND - Non Dim DM - 1-10V Dim	ST - Heavy-Duty Ground Stake with 1/2" NPS Threaded Hub. Built-In Wiring Compartment with 1/2" Coin Plugs. Black Molded Plastic. Use for Line Voltage Applications. 19" Tall with 9" Wide Stabilizer. PS - Black Plastic Ground Stake with 1/2" NPT Threads. Use for 12V Applications. 11" H x 3" Diameter



Vivid Leds, Inc.
PO BOX 9
Sellersburg, IN 47172
800-974-3570
www.vividleds.us

Dimensions, specifications, and product pictures are subject to change without notice.

B13