

Specification:

- Die-cast 6063 aluminum alloy housing with 180 degree rotating mounting brackets
- Four DMX channels
- Input Voltage: 100-240 VAC
- Operating Voltage: 24VDC
- Protection Rating: IP65
- Operating temperature: -20 to 40 celsius
- Certifications: CE, RoHS, ETL

Power and Signal Cable Connection:

- 5' power cable whip and 1.5' in and out DMX cable standard option
- 1.5' power cable in and out and 1.5' DMX cable in and out linkable option
- Field installed grounded plug option for the power cable
- Standard option or linkable option must be selected upon ordering
- Power cable: Line (Black), Neutral (White), Ground (Green)

Standard Option Wiring:

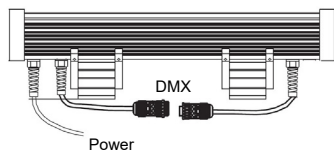

- When connecting the fixture to the controller or connecting the DMX cables between the fixtures, the male connector on the fixture is the input and the female connector is the output. Make sure the first fixture coming from the controller is attached to the correct input cable.
- 5' power cable whip and 1.5' in and out DMX cable included.
- Cables are permanently assembled to the fixture for IP65 use.
- Proprietary waterproof connectors attached for connecting DMX cable.
- Assembled signal cable extenders available with waterproof connectors.
- Individual IP68 connectors can be purchased for use with signal bulk cable.
- A DMX terminator should be used to terminate the last fixture.
- Maximum DMX run is 300' or 60 fixtures and signal amplifiers are available for extended runs.
- For outdoor use, it is recommended to heat shrink over all connectors for long life installation.

Linkable Option Wiring:

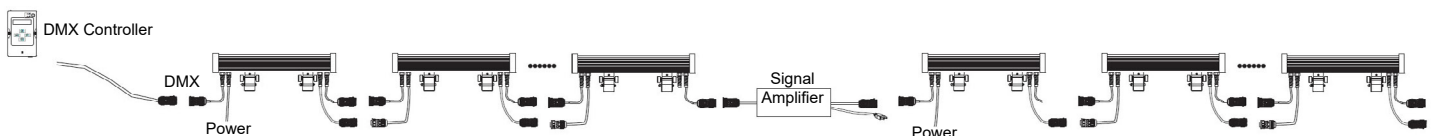

- When connecting the fixture to the controller or connecting the DMX cables between the fixtures, the male connector on the fixture is the input and the female connector is the output. Make sure the first fixture coming from the controller is attached to the correct input cable.
- 1.5' power cable in and out and 1.5' DMX cable in and out included and permanently assembled to the fixture.
- Proprietary waterproof connectors attached for linking DMX and power cable.
- Assembled signal and power extenders available with waterproof connectors.
- Individual IP68 connectors can be purchased for use with signal and power bulk cable.
- A DMX terminator should be used to terminate the last fixture.
- Maximum DMX run is 300' or 60 fixtures and signal amplifiers are available for extended runs.
- The power cable is rated at 5 amps. Caution needs to be taken not to overload the linkable connection.
- For outdoor use, it is recommended to heat shrink over all connectors for long life installation.

Control Options:

- Dimming capability by any DMX controller or built-in controls
- RGBW color changing modes by any DMX 512 controller, or built-in controls
- LED screen with push button control to change or built-in programs or setup DMX
- Built-in self-control in independant mode with pre-programmed lighting effects
- Programs include solid colors, flashing, fading, color jumping
- Fixture modes: 1) Independant, 2) DMX , 3) Master/Slave

1) Independant Mode:

- Using the screen on the side of the fixture. Press "A" four times until "PXY" is displayed. Press "A" once and then select the parameters of your choice. This will change the "P" function with the corresponding numbers in this chart. Press "B" to select the dimming level or speed 1-9. Example: P29 would be green full on.

1 - Red	1-9 Dimming Level
2 - Green	1-9 Dimming Level
3 - Red + Green	1-9 Dimming Level
4 - Blue	1-9 Dimming Level
5 - Blue + Red	1-9 Dimming Level
6 - Blue + Green	1-9 Dimming Level
7 - Red + Green + Blue	1-9 Dimming Level
8 - White	1-9 Dimming Level
9 - White + Red	1-9 Dimming Level
A - White + Green	1-9 Dimming Level

B - White + Red + Green	1-9 Dimming Level
C - White + Blue	1-9 Dimming Level
D - White + Blue + Red	1-9 Dimming Level
E - White + Blue + Red	1-9 Dimming Level
F - WT + Red + Green + BL	1-9 Dimming Level
G - Multicolor Changing	1-9 Speed
H - Single Color Fading	1-9 Speed
I - Multicolor Fading	1-9 Speed
J - Multicolor Flashing	1-9 Speed
K - Autorun Demo Mode	1-9 Speed

2) DMX Mode:

- It is best to set the first fixture to 004. If not, the fixture may be confused as a different mode if setting it to 001. The fixture uses four DMX channels. The first fixture should be 004, the next fixture 008, the next 012, and so on.
- Using the screen on the side of the fixture, when the digital LED is not flashing, press "A" once and the digital LED will begin to flash. Press "A" until you reach the desired DMX channel's first digit. Press "B" to select the next digit and "A" to change the desired channel's second digit. Repeat for the third digit. Once you have programmed the desired DMX channel's address, wait a moment for the screen to stop flashing. This will lock in the DMX address. Connect a DMX controller to operate the fixture.
- If there is no DMX signal present, meaning the DMX cable is not connected, the controller is not connected, or there simply is no DMX signal, the fixture will default to independant mode automatically until a DMX signal is present. For example, if the light fixtures are turned on before the controller, the fixture will first start in independant mode. As soon as a controller is attached, the fixture will go into DMX mode automatically and behave to the setting stored in the controller.
- If all of the steps are followed and the fixture will not go into DMX mode, check all of the cabling for a DMX signal.

3) Master/Slave Mode:

- Choose any one fixture to be the master. With all of the fixtures connected using DMX cables, set all other fixtures to 004. Next, change the master fixture to one of the "P" modes as described above under independant mode. When changing the mode, all other fixtures will change at the same exact time.
- Using the screen on the side of the fixture, when the digital LED is not flashing, press "A" once and the digital LED will begin to flash. Press "A" until you reach the desired DMX channel's first digit. Press "B" to select the next digit and "A" to change the desired channel's second digit. Repeat for the third digit. Once you have programmed the desired DMX channel's address, wait a moment for the screen to stop flashing. This will lock in the DMX address.
- Follow instructions above under independant mode to change the fixtures to the desired programs using the master.

Mounting Brackets:

- Even though both mounting brackets can rotate 180 degrees (90 degrees to either side), it is best to choose the bracket that is the closest match for your application. The side mounting bracket is best used when mounting to a wall, when the fixture is pointing straight up or at an angle. The bottom bracket is best when mounting the fixture on the ground, or on the ledge of a building, pointing straight up or at an angle.
- The brackets are adjustable by loosening the screws to slide the bracket left or right on the fixture for best placement on the surface.
- The angle is adjustable by two twist knobs on the side of the bracket.
- The brackets can be fixed to the surface with M4 or similar tapping screws.
- The fixture will arrive with the brackets installed and cannot be removed from the fixture.

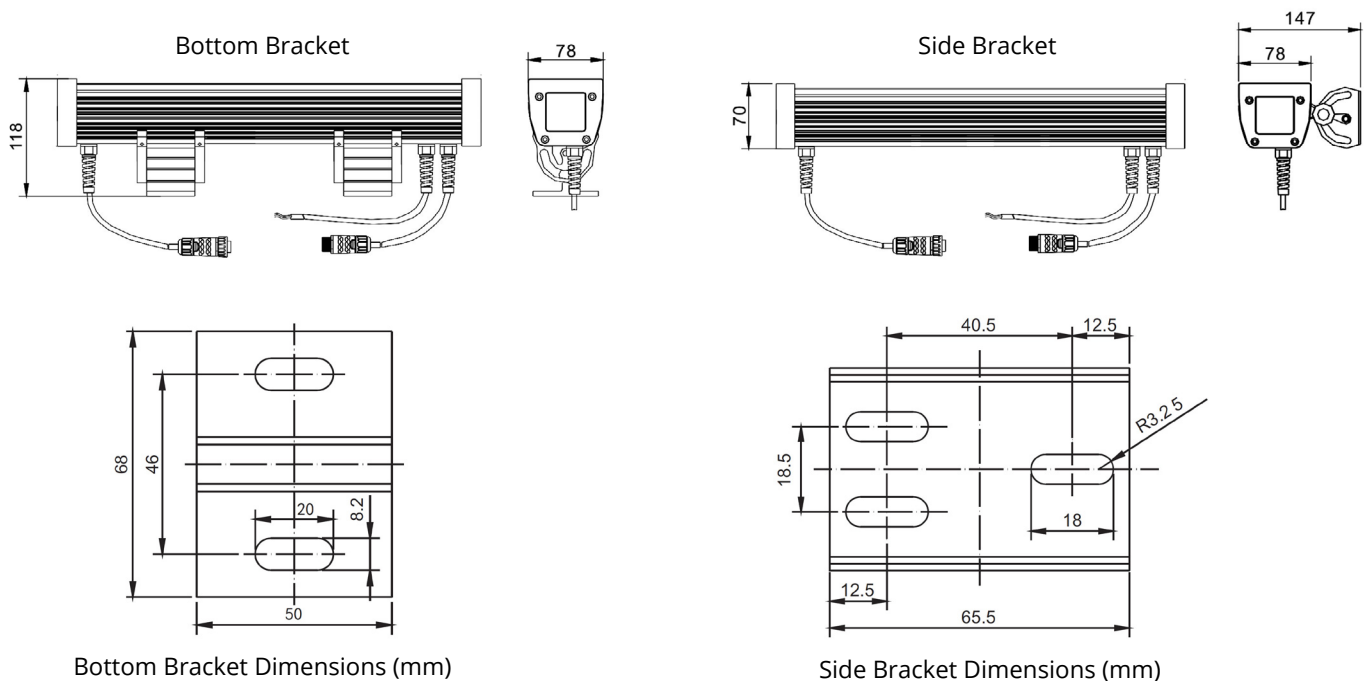

Cautions and Warnings:

- When connecting the fixture to power, make sure and use the ground connection, to avoid electric shock, due to the metal housing.
- Care should be taken to properly heatshrink any connectors to make sure water doesn't seep into the cables. Not doing so will void the IP65 listing and warranty.
- Do not power on the fixture while it is still in the package.
- Do not use anything that covers the fixture's LED or heatsink during operation.
- Do not use the fixture in an enclosed environment.
- If the fixture appears damaged or is malfunctioning, do not attempt to repair, contact Vivid Leds, Inc. for troubleshooting.
- Check local building and electrical codes before assuming this product can be used for your project.