

Product Description

The Focus series LED bulkhead is designed to replace HID lighting systems up to 100w MH or HPS. The diffused polycarbonate lens allows for maximum light output. Typical applications include office and public buildings, condominiums, schools, shopping malls, and hospitality. Recommended mounting heights are 8 to 20 feet.

> Quick Ship - In Stock, Ready to Ship

Project:		Type:
Location:		
Prepared By:		Date:
Comments:		

Performance Summary

- Samsung LEDs with high efficacy >145 Lm/W
- USA assembled product with quick warranty support
- Standard design with modern components, excellent choice for retrofitting
- Patented heat dissipation design for optimum efficiency
- National listing lab tested to IES standards with Type IV optic
- High lumen maintenance exceeds DOE requirements
- Photometric optic built over each LED for enhanced light distribution
- Solid State with high-shock and vibration resistance
- Aluminum LED boards with copper tracings for best thermal management
- LED array manufactured using a state-of-the-art SMT machine
- Diffused polycarbonate opal lens eliminates hot spots
- A360 extruded ingot die-cast housing and front frame
- Integral heatsink and driver compartment
- DuPont textured architectural powdercoat finish in bronze or white
- Chromate conversion coating for long lasting appearance
- Excellent resistance to corrosion, UV degradation and abrasion
- Custom housing colors available upon request
- Rust resistant stainless steel hardware with durable nickel-plating
- Fin heatsinks for best heat dissipation and long life
- High CRI - RA>85 enhances original colors
- 0-10V dimmable driver standard with surge protection
- Standard 2kV internal surge protection, 20kA optional
- Fast turn on with no warm up or cold start issues
- Contains no mercury, lead, infrared or UV radiation and cool to the touch
- Operating temperature: -40 to 50 degrees celsius
- Samsung chip platform with completed 6,000 hour LM-80 test
- 187,000 hour LED life @ L70 tested at 25 degrees celsius
- Certifications: CE, RoHS, CSA - IP66 outdoor rated
- **10 year limited warranty**

FOCUS BULKHEAD

Half Cutoff Polycarbonate Lens 12.5" Round Bulkhead
LED Dimmable Luminaire



Models:

- VDWPR12: 12W - 1792 Lm - B:1, U:1, G:0 - 120-277V
- VDWPR17: 17W - 2509 Lm - B:1, U:1, G:0 - 120-277V
- VDWPR25: 25W - 3763 Lm - B:2, U:1, G:0 - 120-277V, 347-480V

Ordering Information:

Part Number:

*Adder Applies

**Adder Applies. Extended Lead Time May Apply.

Ordering Example: VDWPR25-50-S4C-V27-BZ-ND

Family	CCT	Optic	Voltage	Finish	Housing Type	Accessories*
VDWPR12 VDWPR17 VDWPR25	30 - 3000K 40 - 4000K 50 - 5000K	S4C - Type IV Short	V27 - 120-277V V48 - 347-480V*	WT - White BZ - Bronze CS - Custom**	A - Half Cutoff B - Open Frame C - Grid Frame D - Grid Frame E - Open Frame F - Half Cutoff	SP1 - 20kA Surge Protection 120-277VAC SP2 - 20kA Surge Protection 347-480VAC EM - Emergency Driver Provides 90 Minutes of Backup Power MS1 - Internal Microwave On/Off Sensor 8' to 19' - 120-277V MS2 - Internal Microwave Dimming Sensor up to 15' - 120-277V PP - Pencil Photocell 120-277V 1/2" CdS PC - Button Photocell 120-277V 1/2" CdS



Vivid Leds, Inc.
PO BOX 9
Sellersburg, IN 47172
800-974-3570
www.vividleds.us

Dimensions, specifications, and product pictures are subject to change without notice.

Dimensions:

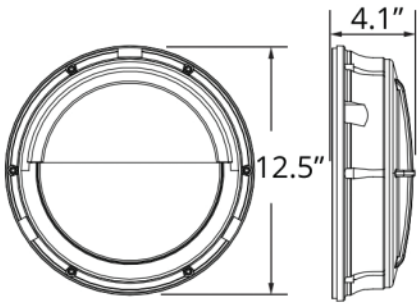

Type A

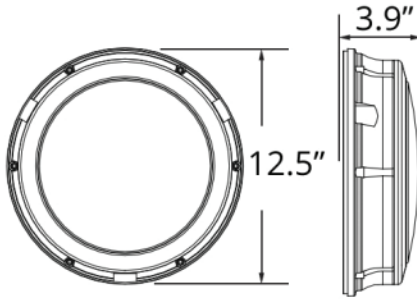

Type B

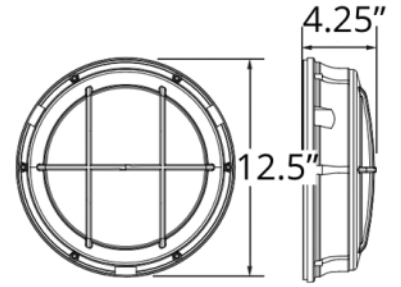

Type C

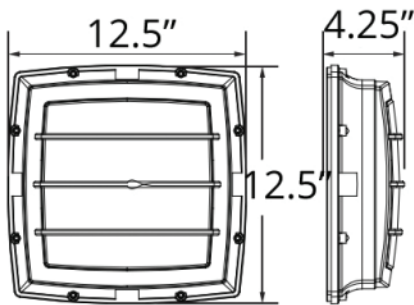

Type D

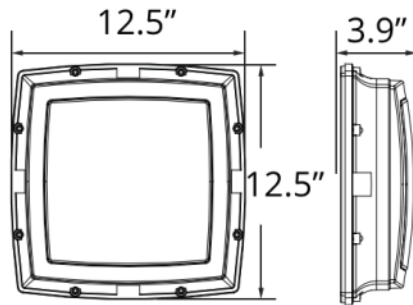

Type E

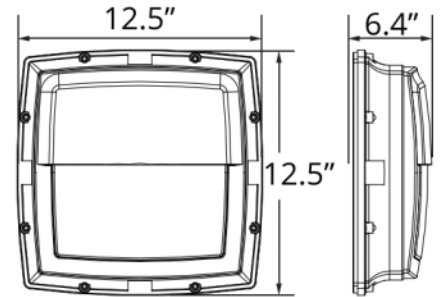

Type F

