

VEGA2 ARA INSTRUCTION

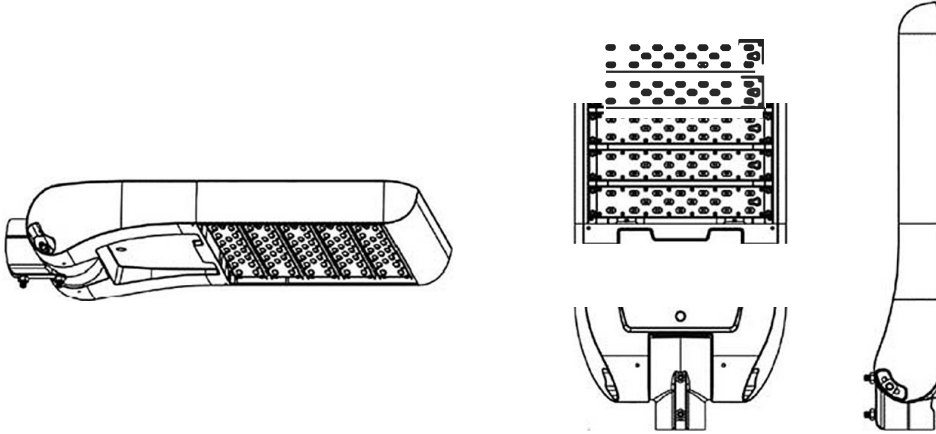

**PLEASE READ THESE INSTRUCTIONS CAREFULLY BEFORE INSTALLATION
LEAVE A COPY FOR THE USER / MAINTENANCE ENGINEER FOR FUTURE REFERENCE**

IMPORTANT INSTALLATION INFORMATION

- Before commencing installation or maintenance, ensure electricity is switched off at the mains. Installation or maintenance should be carried out by a qualified electrician.
 - The luminaire must not, under any circumstances, be installed directly to flammable materials, and luminaires must not be covered with any flammable materials.
 - Ensure there is adequate free air circulation of at least 50cm around the luminaire. All luminaires run hot. It is the installer's responsibility to consider fire risk and take appropriate precautions.
-

INSTALLATION INSTRUCTION

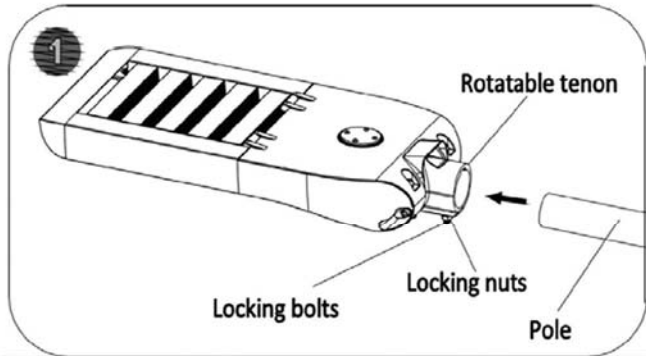

STEP 1: Loosen nuts from pole locking bolts, then slide fixture on to pole through opening (tenon) on the rear of housing. **See Figure 1.**

STEP 2: Ensure to slide fixture to the inner end of tenon, then tighten locking bolts with 5mm hex wrench or its equivalent to ensure the fixture is fixed to pole firmly. **See Figure 1.**

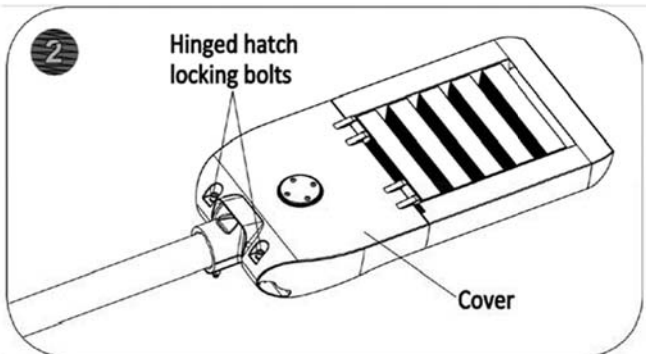

STEP 3: Loosen hinged hatch locking bolts with 5mm hex wrench or its equivalent, and open the hatch for led driver compartment access. **See Figure 2.**

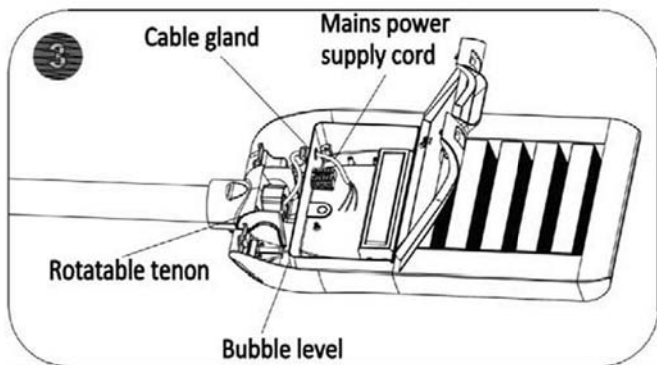

STEP 4: Get mains power supply cord into led driver compartment via cable gland, and use open spanner or similar tool to lock the gland to mains power supply cord tightly. **See**

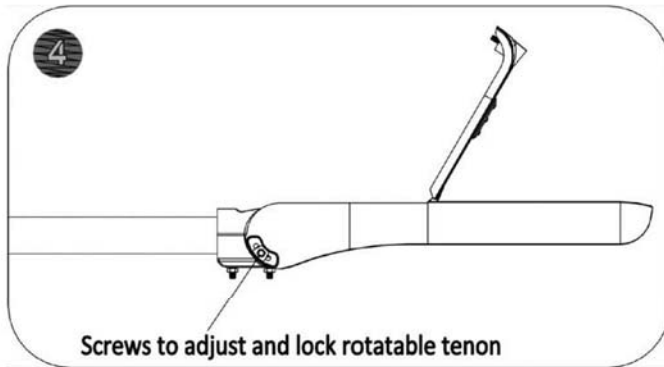

STEP 5: To adjust tilting angles from front to back, firstly loosen the screws on both sides of the rotatable tenon using 6mm hex wrench or its equivalent, **see Figure 4**. Secondly locate the tilt and fix it by tightening the mentioned screws at 45 N.m.torque. To adjust the fixture from side to side, loosen the pole locking bolts, **see Figure 1**, when ready, tighten the pole locking bolts at 45 N.m, then tighten the pole locking nuts at 10 N.m torque so as to ensure the lighting fixture is installed to the pole firmly.

IMPORTANT - DO NOT exceed the torque level on the mount bolts. Exceeding recommended torque value resulting in excessive deformation of pole mounting bracket will cause stripping of mount hardware which could lead to an unsafe mounting condition.

STEP 6: Reference “Electrical Connections” section for completing electrical connections. **See Figure 6**.

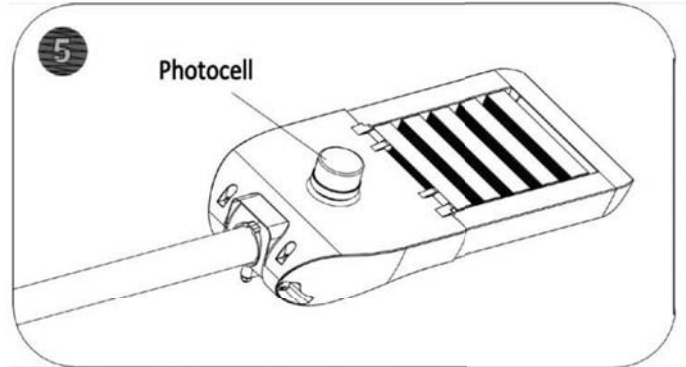

PHOTOELECTRIC CONTROLLER INSTALLATION (OPTIONAL)

- STEP A:** Make sure a NEMA receptacle on top of fixture is available.
- STEP B:** Find out the size difference of three pins on P.E.C.U., the size difference of three slots on NEMA receptacle.
- STEP C:** Insert P.E.C.U. in receptacle, and twist it clockwise firmly.
- STEP D:** Firmly rotate photo-control with its photo-eye approximately in the ‘N’ north direction. Some photo-controls operate best somewhere between NW and NE. **See Figure 5**.

WIRING INSTRUCTION

- STEP I:** Connect the LINE wire in the mains power supply cord to the L marked hole in the terminal block from the external junction box, and tighten the connection properly.
- STEP II:** Connect the NEUTRAL wire in the mains power supply cord to the N marked hole in the terminal block from the external junction box, and tighten the connection properly.
- STEP III:** Connect the YELLOW/GREEN GROUNDING wire in the mains power supply cord to the G marked hole in the terminal block from the external junction box, and tighten the connection properly.
- STEP IV:** Close front lid, and tighten the locking screws firmly.

