

Product Description

The Array FC series full cutoff wall pack luminaire is the perfect choice for security, pathway and perimeter lighting, building entryways and walkways. Realize all of the features of a high quality unit with Philips LEDs, a sealed die cast housing, powdercoat, and UV lens, while maintaining a budget price. Look no further than the Array series to deliver ourstanding performance for years to come.

> Quick Ship - In Stock, Ready to Ship

Project:		Type:
Location:		
Prepared By:		Date:
Comments:		

Performance Summary

- Philips Lumileds 3030 LEDs with high efficacy >120 Lm/W
- Standard design with modern components, excellent choice for retrofitting
- Low profile, 3G vibration rated compact design prescribed by ANSI C136.31
- Patented heat dissipation design for optimum efficiency
- National listing lab tested to IES standards with Type III optic
- Photometric optic built over each LED for enhanced light distribution
- Optics are precisely designed to shape the distribution, maximizing efficiency
- High lumen maintenance exceeds DOE requirements
- Solid State with high-shock and vibration resistance
- Thermal management design with low junction temperature
- Extremely light weight for safety in use and installation
- Rugged A360 die-cast housing with integral heat sink
- Housing is completely sealed against moisture and environmental contaminants
- Aluminum LED boards with copper tracings for best thermal management
- LED array manufactured using a state-of-the-art SMT machine
- Light engine is available in a 5000K (70 CRI) configuration
- Polycarbonate optical lens with UV stabilizers provide outstanding performance
- Architectural bronze powdercoat finish
- Chromate conversion coating for long lasting appearance
- LED driver features short circuit, over current, over voltage, over temp protection
- 1/2" coin plugs with o-rings for conduit and optional button photocell
- 90 minute emergency backup kit can be attached to the fixture
- Emergency backup provides 8W and 900 lumens of illumination
- Rust resistant stainless steel hardware with durable nickel-plating
- Cast-in template for mounting directly over a 4" recessed outlet box
- Can also be direct wall surface mounted with 1/2" entry for conduit
- Fast turn on with no warm up or cold start issues
- 1/9th micro color binning enables tight color control
- Hot color targeting ensures color is within ANSI bin compliance
- Contains no mercury, lead, infrared or UV radiation and cool to the touch
- Operating temperature: -40 to 104 degrees F (-40 to 40 degrees C)
- 100,000 hour LED life based on LM-80 results and TM-21 calculation
- Certifications: CE, RoHS, UL, cUL, DLC - IP65 outdoor rated
- 5 year system warranty

ARRAY FC SERIES

Full Cutoff Wall Pack
LED Luminaire



Models:

- VDMWP02045: 45W - 4900 Lm - 9.5 Lbs
- VDMWP02070: 70W - 7350Lm - 9.8 Lbs
- VDMWP02090: 90W - 9500 Lm - 12.9 Lbs
- VDMWP02135: 135W - 14000 Lm - 13.1 Lbs

Ordering Information:				Part Number:		
Ordering Example: VDMWP02045-50-T3-V27-BZ-ND						
Family	CCT	Optic	Voltage	Finish	Dimming	Accessories
VDMWP02045 VDMWP02070 VDMWP02090 VDMWP02135	50 - 5000K	T3 - Type III Clear Lens	V27 - 120-277V	BZ - Bronze	ND - Non Dim	PC - Button Photocell 100-277V EM - Emergency Backup Kit



Vivid Leds, Inc.
PO BOX 9
Sellersburg, IN 47172
800-974-3570
www.vividleds.us

Dimensions, specifications, and product pictures are subject to change without notice.

Dimensions:

Models: 45W, 70W

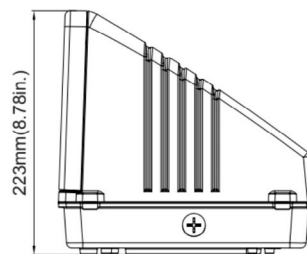
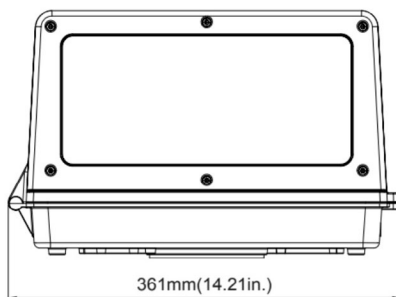
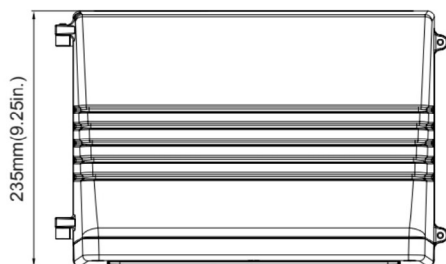

Models: 90W, 135W

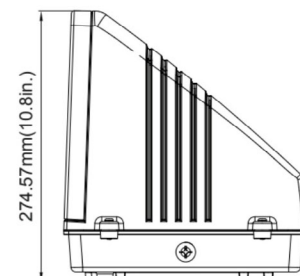
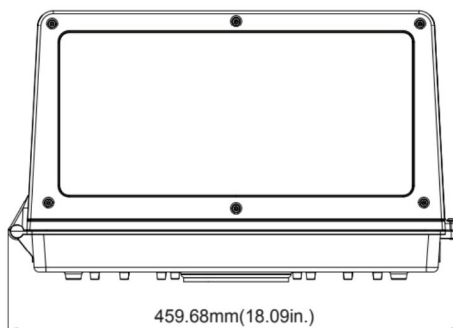

Photometrics:

Models: 45W, 70W

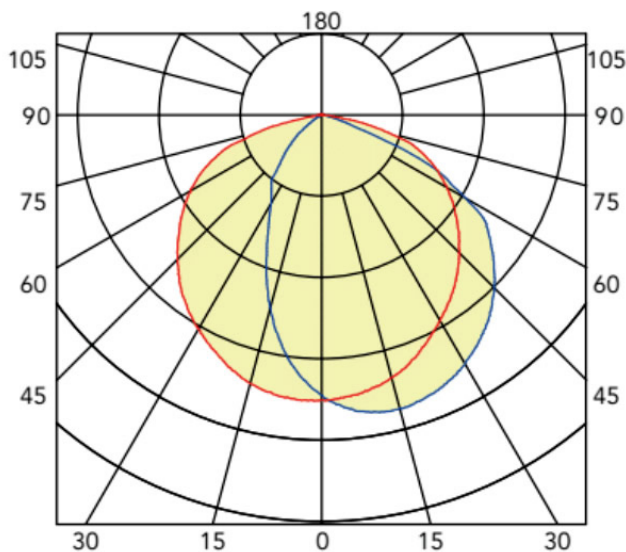

Models: 90W, 135W

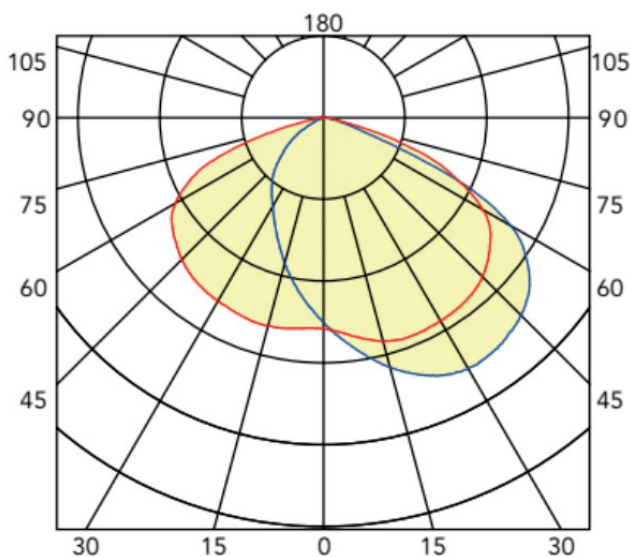

Vivid Leds, Inc.
PO BOX 9
Sellersburg, IN 47172
800-974-3570
www.vividleds.us

Dimensions, specifications, and product pictures are subject to change without notice.

