

Product Description

The Industry EM Series is a decorative LED Wall Pack that provides down lighting with a uniform distribution designed to replace compact fluorescent lighting systems. Typical wall mounted applications for a variety of project types provides security lighting near doors and entrances with integral photocell or switching control. Mounting heights of 8 to 12 feet can be used based on light level and uniformity requirements

> Quick Ship - In Stock, Ready to Ship

Project:		Type:
Location:		
Prepared By:		Date:
Comments:		

Performance Summary

- Samsung LEDs with high efficacy >70 Lm/W
- USA assembled product with quick warranty support
- Standard design with modern components, excellent choice for retrofitting
- Installed photocell is internally wired for switching between wall switch or photocell
- Patented heat dissipation design for optimum efficiency
- National listing lab tested to IES standards with Type IV optic
- High lumen maintenance exceeds DOE requirements
- Solid State with high-shock and vibration resistance
- Aluminum LED boards with copper tracings for best thermal management
- LED array manufactured using a state-of-the-art SMT machine
- Molded prismatic UV resistant polycarbonate lens with high quality gasket
- A360 extruded ingot die-cast vandal resistant housing and ballast box
- DuPont textured architectural bronze or white powdercoat finish
- Chromate conversion coating for long lasting appearance
- Custom housing colors available upon request
- 1/2" coin plugs with o-rings for conduit
- Cast-in template for mounting directly over a 4" recessed outlet box
- Accessible to mount by 1/2" surface conduit
- Rust resistant stainless steel hardware with durable nickel-plating
- Fin heatsinks for best heat dissipation and long life
- High CRI - RA>80 enhances original colors
- 1/9th LED micro color binning enables tight color control
- Hot color targeting ensures color is within ANSI bin compliance
- Fast turn on with no warm up or cold start issues
- Contains no mercury, lead, infrared or UV radiation and cool to the touch
- Operating temperature: -20 to 40 degrees celsius
- Samsung chip platform with completed 6,000 hour LM-80 test
- 84,000 hour LED life @ L70 tested at 105 degrees celsius
- Certifications: CE, RoHS, CSA, ADA Compliant - IP65 outdoor rated
- 5 year system warranty

INDUSTRY EM SERIES

Vandal Resistant Decorative Wall Pack with EM Option

LED Luminaire

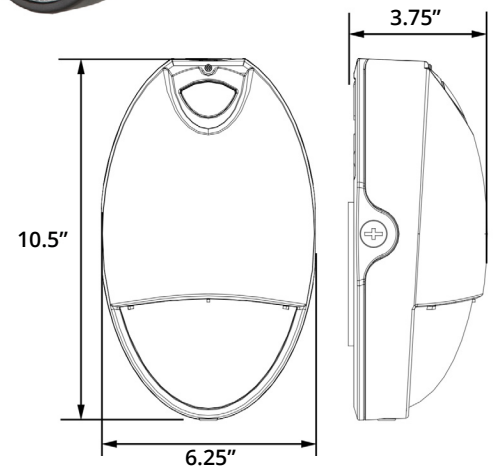

Models:

- WDWPC3: 10W - 729 Lm - 700 mA - B:0, U:3, G:1

Ordering Information:				Part Number:		
*Adder Applies				Ordering Example: WDWPC3-50-S4C-V27-BZ-ND		
Family	CCT	Optic	Voltage	Finish	Dimming	Accessories*
WDWPC3	50 - 5000K	S4C - Type IV	V27 - 120-277V	BZ - Bronze WT - White	ND - Non Dim	EM - NiCad Battery Backup (4.8V, 2500mAh). Supplies 90 Minutes of Emergency Operation. 170 Lumen Output in Emergency Mode. Self-Test/Self Diagnostics Included. Low-Voltage Battery Disconnection Prevents Deep Battery Discharge Damage. 24 Hour Recharge After 90 Minute Discharge.



Vivid Leds, Inc.
PO BOX 9
Sellersburg, IN 47172
800-974-3570
www.vividleds.us

Dimensions, specifications, and product pictures are subject to change without notice.

The product on this page is a manufactured to order, non-stocking item. This product cannot be returned for refund or credit.

D12

Revised 6.30.19