

Product Description

The Industry series is a ARRA compliant wall mount luminaire using the latest Samsung LEDs. From benchmarking a minimum 104 degree F ambient during thermal testing, to custom designed LED arrays for each luminaire individually, to using the best housing materials and coatings, each aspect has been taken into careful consideration to ensure many years of trouble-free service.

> Quick Ship - In Stock, Ready to Ship

Project:		Type:
Location:		
Prepared By:		Date:
Comments:		

Performance Summary

- Samsung LEDs with high efficacy >60 Lm/W
- USA assembled product with quick warranty support
- Standard design with modern components, excellent choice for retrofitting
- Patented heat dissipation design for optimum efficiency
- National listing lab tested to IES standards with Type V optic
- High lumen maintenance exceeds DOE requirements
- Solid State with high-shock and vibration resistance
- Aluminum LED boards with copper tracings for best thermal management
- LED array manufactured using a state-of-the-art SMT machine
- Molded prismatic borosilicate glass lens with high quality gasket
- A360 extruded ingot die-cast housing and ballast box
- DuPont textured architectural bronze powdercoat finish
- Chromate conversion coating for long lasting appearance
- Custom housing colors available upon request
- 1/2" coin plugs with o-rings for conduit and photocell
- Cast-in template for mounting directly over a 4" recessed outlet box
- Accessible to mount by 1/2" surface conduit
- Rust resistant stainless steel hardware with durable nickel-plating
- Fin heatsinks for best heat dissipation and long life
- High CRI - RA>85 enhances original colors
- 1-10V dimmable driver with surge protection option
- Fast turn on with no warm up or cold start issues
- Contains no mercury, lead, infrared or UV radiation and cool to the touch
- Operating temperature: -40 to 50 degrees celsius
- Samsung chip platform with completed 6,000 hour LM-80 test
- 100,000 hour LED life @ L70 tested at 105 degrees celsius
- Certifications: CE, RoHS, CSA - IP65 outdoor rated
- 5 year system warranty

INDUSTRY EL SERIES

Square Wall Pack
LED Dimmable Luminaire

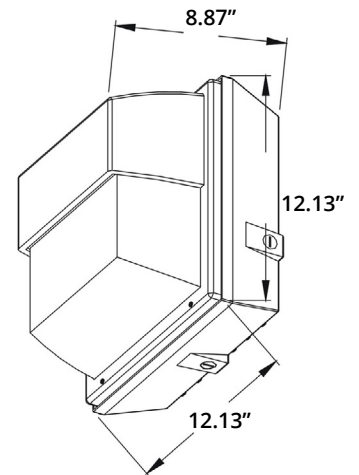

Models:

- VDWPS30QF: 45W - 2600 Lm

Ordering Information:				Part Number:		Ordering Example: VDWPS30QF-50-S5C-V27-BZ-ND
*Adder Applies		**Adder Applies. Extended Lead Time May Apply.				
Family	CCT	Optic	Voltage	Finish	Dimming	Accessories*
VDWPS30QF	30 - 3000K** 40 - 4000K** 50 - 5000K	S5C - Type V Short 115 Degree	V27 - 120-277V	BZ - Bronze CS - Custom*	ND - Non Dim DM - 1-10V Dim	SF - Single Fuse DF - Double Fuse SP - 20kA Surge Protection 120-277VAC



Vivid Leds, Inc.
PO BOX 9
Sellersburg, IN 47172
800-974-3570
www.vividleds.us

Dimensions, specifications, and product pictures are subject to change without notice.