

## Product Description

The Array Dusk to Dawn series is an affordable solution to illuminate backyards, service roads, garage areas, and fields. The fixture combines optical performance, energy efficiency and versatility to meet the needs of any area. It is effective for security and perimeter lighting for many applications. Applicable to a variety of diameter installations, 1 5/8" to 2 3/8" compatible, suitable for wall and pole installation.

> Quick Ship - In Stock, Ready to Ship

Project:		Type:
Location:		
Prepared By:		Date:
Comments:		

## Performance Summary

- Lumileds 3030 LEDs with high efficacy >140 Lm/W
- Low profile, 3G vibration rated compact design minimizes wind loads
- Patented heat dissipation design for optimum efficiency
- National listing lab tested to IES standards in a Type V distribution
- High lumen maintenance exceeds DOE requirements
- Photometric optic built over each LED for enhanced light distribution
- Solid State with high-shock and vibration resistance
- Mount directly to the wall or to a pole
- Fixture pole opening accepts 1 5/8" to 2 3/8" diameter
- LED drivers mount to housing for optimal heat sinking and prolonged life
- Aluminum LED boards with copper tracings for best thermal management
- LED array manufactured using a state-of-the-art SMT machine
- Light engine is available in a 5000K (70 CRI) configuration
- Optics are precisely designed to shape the distribution, maximizing efficiency
- Rugged one-piece A360 die-cast housing with integral heat sink and power door
- Housing is completely sealed against moisture and environmental contaminants
- Architectural silver gray powdercoat finish
- Chromate conversion coating for long lasting appearance
- Rust resistant stainless steel hardware with durable nickel-plating
- Button photocell included
- Fast turn on with no warm up or cold start issues
- 1/9th micro color binning enables tight color control
- Hot color targeting ensures color is within ANSI bin compliance
- Contains no mercury, lead or UV radiation and cool to the touch
- Operating temperature: -40 to 113 degrees F (-40 to 45 degrees C)
- 100,000 hour LED life based on LM-80 results and TM-21 calculation
- Certifications: CE, RoHS, UL, cUL, DLC - IP65 outdoor rated
- 5 year system warranty

## ARRAY SM SERIES

Dusk to Dawn Barn Style

LED Luminaire

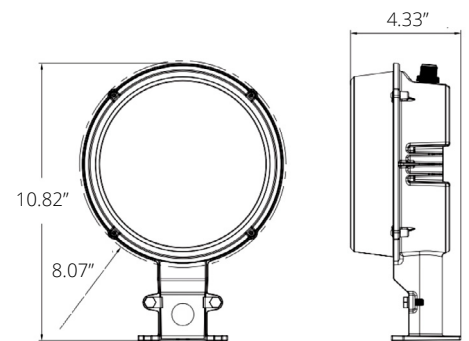

## Models:

- WDMDD0327: 27W - 3850 Lm - 2.2 Lbs
- WDMDD0340: 40W - 5650 Lm - 2.4 Lbs

Ordering Information:				Part Number:		
*Adder Applies				Ordering Example: WDMDD0327-50-T5-V27-SG-WM		
Family	CCT	Optic	Voltage	Finish	Mounting	Accessories*
WDMDD0327 WDMDD0340	50 - 5000K	T5 - Type V	V27 - 120-277V	SG - Silver Gray	WM - Wall Mount	PL - Quantity 6 Mast Arm Poles 1 5/8" Diameter



Vivid Leds, Inc.  
PO BOX 9  
Sellersburg, IN 47172  
800-974-3570  
www.vividleds.us

Dimensions, specifications, and product pictures are subject to change without notice.

A22

