

Product Description

The Maize series is an exceptional product with a track record of 8 years in the field. We use the latest technology and continue to raise the bar in terms of housing quality, lamp efficacy, and overall extended lifespan. Using only top quality components such as Rubycon capacitors, flame retardant materials, a water resistant cover, and LG LEDs, the Maize series is a market leader for commercial applications.

> Standard Ship - 30 Day Lead Time

Project:		Type:	
Location:			
Prepared By:		Date:	
Comments:			

Performance Summary

- LG 3030 SMD LED with high efficacy >120 Lm/W
- National listing lab tested with IES standards
- Excellent solution for retrofitting 400W HID lamps
- 180 degree one-sided output for maximum coverage
- 350 degree twistable base to direct light to the right spot
- Folding mechanism integrated into the lamp for fast and easy installation
- Bypass the ballast and use the Internal driver for easy installation
- Fast turn on, no warm up or cold start problems
- Integrative LED design for heatsink and housing
- High quality aluminum heatsink for best heat dissipation
- Suitable for totally enclosed fixtures
- Polycarbonate lens cover provides IP64 protection
- Crystal clear lens for maximum lumen output
- Diffused lens reduces glare and enhances appearance
- Rubycon capacitance power for best protection
- Integrated 6KV surge protection
- Contains no mercury or lead and cool to the touch
- No infrared or UV radiation
- Flame retardant housing material
- High CRI - RA>80 enhances original colors
- Power factor: >.90
- Operating temperature: -40 to 60 degrees celsius
- 100,000 hour LED life
- Certifications: CE, PSE, TUV, RoHS, FCC, cUL, UL, DLC
- 1 year system warranty

MAIZE HORIZONTAL HP SERIES

HID Retrofit LED Lamp



Models:

- WDS3580: 120 LEDs - 80W - 9600 Lm - 2.7 Lbs
- WDS3511: 168 LEDs - 110W - 13200 Lm - 3.6 Lbs

Applications: Street Light, Cobra Head, Shoebox

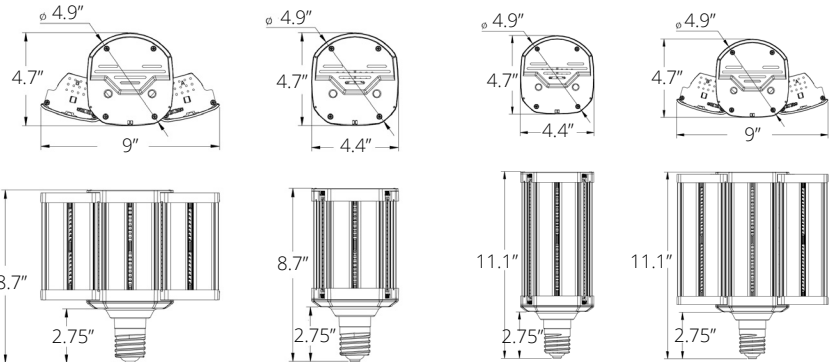

Ordering Information:

Part Number:

Ordering Example: WDS3580-30-T5-UNV-CL-E39

Family	CCT	Optic	Voltage	Lens Cover	Base Type
WDS3580 WDS3511	30 - 3000K 40 - 4000K 50 - 5000K 57 - 5700K	T5 - Type V 180 Degree	UNV - 100-277V	CL - Clear DF - Diffused	E39 - Mogul EX39 - Mogul



Vivid Leds, Inc.
PO BOX 9
Sellersburg, IN 47172
800-974-3570
www.vividleds.us

Dimensions, specifications, and product pictures are subject to change without notice.

Cautions:

Remove ballast before installing
Check dimensions of lamp for fitment

H1