

Product Description

The Performance Series luminous ceiling panel provides magnificent, long-lasting, light output compared to fluorescent troffers, with at least 50% energy savings. Designed to Energy Star and DLC standards, along with a 100,000 hour LED lamp life and durable quality, you can be assured this light panel luminaire will last for years to come.

> Quick Ship - In Stock, Ready To Ship

Project:		Type:
Location:		
Prepared By:		Date:
Comments:		

Performance Summary

- Epistar 4014 SMD LEDs with high efficacy >95 Lm/W
- Very slim - only 0.35" inch thick
- Multiple dimming options for enhanced control
- Solid state LED light source, instant start, long life
- National listing lab tested with Type V 110 degree distribution
- AL6063 aluminum frame, oxidized for enhanced beauty
- Edge-lit frame allows even light distribution while concealing the LEDs
- Opalescent lens provides a soft, glare-free luminous glow
- Mimics the look of a skylight above the work surface
- Well distributed light using a patented reflecting system
- Effectively illuminates ambient light with superior foot candles
- High quality Polystyrene cover with strong capacity
- Stable performance with isolated external driver in conduit box
- Driver can be remote mounted to fit your application
- Excellent CRI RA>82 for color enhancement
- Delicate shape, lightweight, simple and easy installation
- No UV or RF interference, silent operation, no noise, no flickering
- Anti-collision, impact and vibration resistant
- Quick drop-in, surface mount or suspension kit options
- Earthquake clips included for enhanced drop-in protection
- Erosion protection against hydrochloric acid
- LiFud class 2 driver with power factor: >0.95, THD<15%
- Operating temperature: -20 to 45 degrees celsius
- 100,000 hour LED lamp life
- Certifications: CE, RoHS, UL, cUL, DLC - IP44
- 10 year limited warranty

PERFORMANCE SERIES

Luminous Ceiling LED Panel

2X2, 1X4, 2X4 LED Dimmable Luminaire

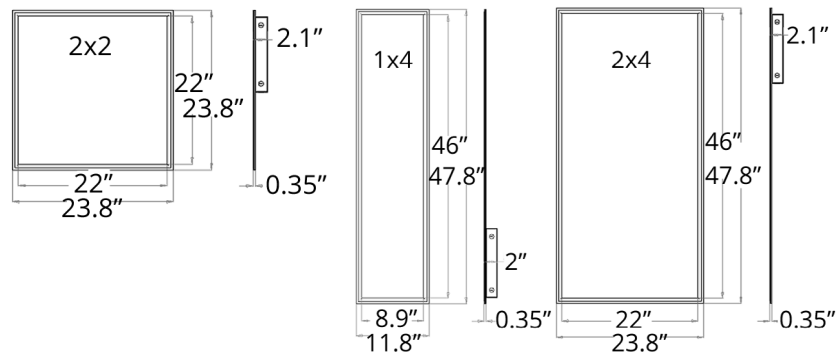
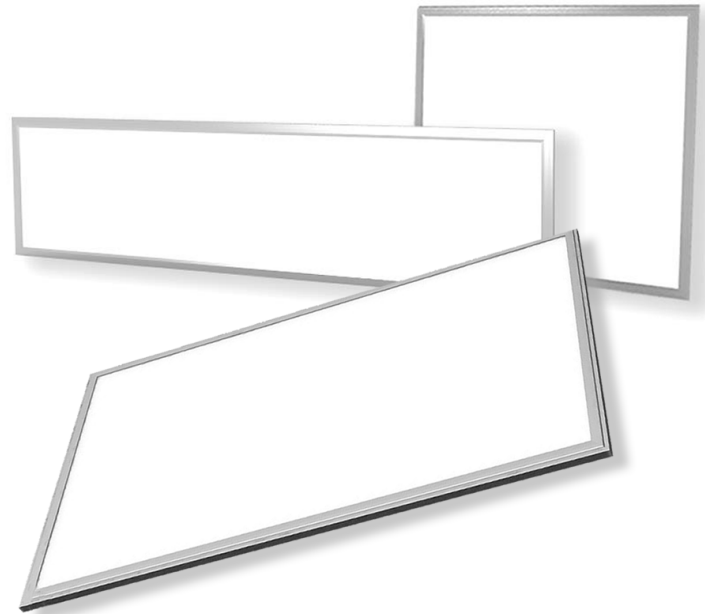

Models:

- WDES2240: 2X2 - 40W - 4950 Lm - 7.9 Lbs
- WDES1440: 1X4 - 40W - 4950 Lm - 8.1 Lbs
- WDES2460: 2X4 - 60W - 5700 Lm - 15.6 Lbs

Ordering Information:

Part Number:

*Adder Applies

Ordering Example: WDES2240-50-DI-UNV-WH-ND

Family	CCT	Mounting	Voltage	Finish	Dimming	Accessories
WDES2240 WDES1440 WDES2460	35 - 3500K 40 - 4000K 50 - 5000K	DI - Drop-in Grid T-bar with Earthquake Clips SF - 2" Height Low Profile Aluminum Surface Mount Kit* SP - Suspension Kit with Hardware and Aircraft Cable*	UNV - 100-240V V27 - 277V	WH - White CS - Custom*	ND - No Dim D1 - 0-10V Dim TM - TRIAC Dim*	ED - Emergency Backup Driver* (2x2 - 8W, 2x4 - 12W)



Vivid Leds, Inc.
PO BOX 9
Sellersburg, IN 47172
800-974-3570
www.vividleds.us

Dimensions, specifications, and product pictures are subject to change without notice.

Delivered lumens listed based on 5000K white CCT

The product on this page is a manufactured to order, non-stocking item. This product cannot be returned for refund or credit.

F1

Revised 6.26.18