

Product Description

The Performance Series luminous ceiling panel provides magnificent, long-lasting, light output compared to fluorescent troffers, with at least 50% energy savings. Designed to Energy Star and DLC standards, along with a 100,000 hour LED lamp life and durable quality, you can be assured this light panel luminaire will last for years to come.

> Quick Ship - In Stock, Ready To Ship

Project:		Type:
Location:		
Prepared By:		Date:
Comments:		

Performance Summary

- Epistar 4014 SMD LEDs with high efficacy >85 Lm/W
- Very slim - only 0.35" inch thick
- Dimming options for enhanced control
- Solid state LED light source, instant start, long life
- National listing lab tested with Type V 110 degree distribution
- AL6063 aluminum frame, oxidized for enhanced beauty
- Edge-lit frame allows even light distribution while concealing the LEDs
- Opalescent lens provides a soft, glare-free luminous glow
- Mimics the look of a skylight above the work surface
- Well distributed light using a patented reflecting system
- Effectively illuminates ambient light with superior foot candles
- High quality Polystyrene cover with strong capacity
- Stable performance with isolated external driver in conduit box
- Driver can be remote mounted to fit your application
- Excellent CRI RA>82 for color enhancement
- Delicate shape, lightweight, simple and easy installation
- No UV or RF interference and Mercury free
- Anti-collision, impact and vibration resistant
- Quick drop-in, surface mount or suspension kit options
- Earthquake clips installed for enhanced drop-in protection
- Erosion protection against hydrochloric acid
- Silent operation, no noise, no flickering
- Power factor: >0.95, THD<15%
- Operating temperature: -20 to 45 degrees celsius
- 100,000 hour LED lamp life
- Certifications: CE, RoHS, UL, cUL, DLC - IP44
- 5 year system warranty

Models:

- WDES22FR: 2X2 - 36W - 3119 Lm - 7.9 Lbs
- WDES14FR: 1X4 - 36W - 3203 Lm - 8.1 Lbs
- WDES24FR: 2X4 - 60W - 5702 Lm - 15.6 Lbs

Delivered lumens based on 5000K white CCT

PERFORMANCE STANDARD SERIES

Luminous Ceiling LED Panel

2X2, 1X4, 2X4 LED Dimmable Luminaire

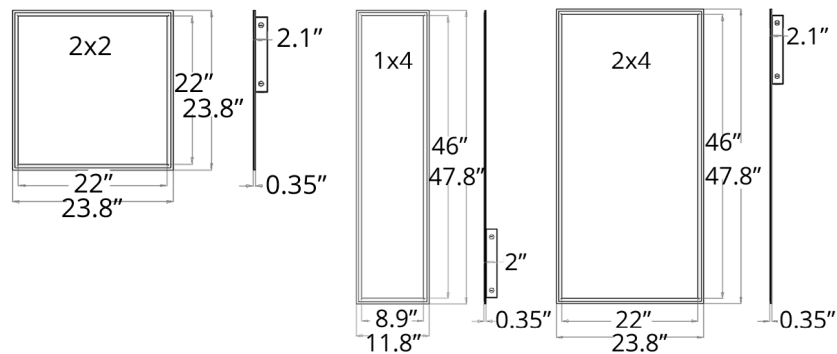
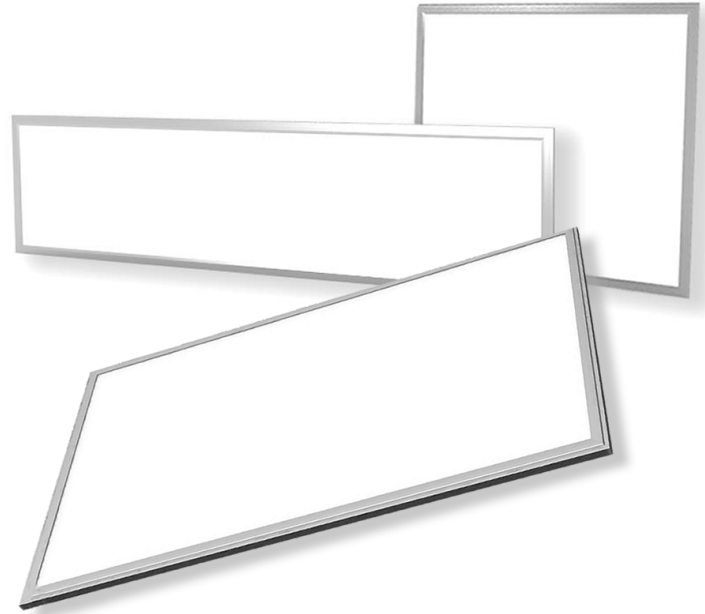

Ordering Information:

Part Number:

*Special Order, Extended Lead Time May Apply, Adder Applies

Ordering Example: WDES22FR-50-DI-UNV-WH-ND

Family	CCT	Mounting	Voltage	Finish	Dimming	Accessories*
WDES22FR WDES14FR WDES24FR	30 - 3000K* 35 - 3500K* 40 - 4000K 50 - 5000K	DI - Drop-in Grid T-bar with Earthquake Clips	UNV - 110-120V V27 - 277V	WH - White GR - Silver Gray* BK - Black* CS - Custom*	ND - No Dim D1 - 0-10V Dim TM - TRIAC Dim* DL - Dali Dim*	ED - Emergency Backup Driver (2x2 - 8W, 2x4 - 12W) SF - 2" Height Low Profile Aluminum Surface Mount Kit SP - Suspension Kit with Hardware and Aircraft Cable



Vivid Leds, Inc.
PO BOX 9
Sellersburg, IN 47172
800-974-3570
www.vividleds.us

Dimensions, specifications, and product pictures are subject to change without notice.

F1