

Instruction Manual LED Emergency Equipment

IMPORTANT SAFEGUARDS

When using electrical equipment, basic safety precautions should always be followed, including the following:

Read And Follow All Safety Instructions

1: CAUTION-TO prevent electrical shock, do not mate unit connector until installation is complete and A.C. power is supplied to the unit.

2: CAUTION-This fixture provides more than one power supply output source. To reduce the risk of electrical shock, disconnect both normal and emergency sources by turning off the A.C. branch circuit and by disconnecting the unit connector.

3: CAUTION-This is a sealed unit. Components are not replaceable. Replace the entire unit when necessary.

4: CAUTION-Installation and servicing should be performed by qualified personnel only. De-energize before opening.

5: DONOT USE OUTDOORS. The LED Emergency Equipment is for use with grounded, UL Listed, damp location rated, indoor fixtures. Not for use in heated air outlets or hazardous locations.

6: The LED Emergency Equipment requires an unswitched A.C. power source of 100-277/120-250V volts. Properly cap the unused A.C. lead.

7: The LED Emergency Equipment and A.C. driver must be on the same branch circuit.

8: Do not mount near gas or electric heaters.

9: The LED Emergency Equipment should be mounted in locations and at heights where it will not readily be subjected to tampering by unauthorized personnel.

10: The LED Emergency Equipment will supply 48VDC output at the individual rated specification for 90 minutes. See individual units for output specifications.

11: Suitable for use in damp locations.

12: For use in 0°C minimum, 50°C maximum ambient temperatures.

13: The use of accessory equipment not recommended by the manufacturer may cause an unsafe condition.

14: Do not use this equipment for other than intended use.

15: Install in accordance with the National Electrical Code and local regulations.

16: Lighting fixture manufacturers, electricians, and end-users need to ensure product system compatibility before final installation.

SAVE THESE INSTRUCTIONS

Installation Instructions

CAUTION: Before installing, make certain the A.C. power is off and the LED Emergency Equipment unit connector is disconnected.

1. Production Information

AC Input	Model	LED Arrays
120-250VAC (UL/CUL)	EL-0848-XXG	8W
	EL-1248-XXG	12W
	EL-2548-XXG	25
100-277VAC (UL)	EL-0848-XXU	8W
	EL-1248-XXU	12W
	EL-2548-XXU	25W

2. Mounting The LED Emergency Equipment

The LED Emergency Equipment should be mounted on or nearby the fixture above the ceiling. The flex conduit marked "A" should be wired into the driver/lamp compartment or to an electrical junction box on the fixture which allows access to the fixture connections. Refer to Illustration 1 for typical mounting.

When battery packs are remote mounted, the remote distance can not exceed 1/2 of the distance from driver to lamp specified by the A.C. driver manufacturer. Under no circumstances should the battery pack exceed a distance of 50' from the lamp.

3. Wiring

Refer to the wiring diagram on the back page for the appropriate wiring of the LED load and driver. Install in accordance with the National Electrical Code and local regulations. For additional wiring diagrams consult Customer Service.

4. Mounting The Test Accessories

Cut a single gang switch box into the ceiling tile adjacent to the fixture within reach of the LED Emergency Equipment flex. After mounting the switch box, connect flex to the box and route all leads inside the box. Note proper polarity of the charge indicator light prior to removal from harness.

Illustration 1 Downlight Fixture

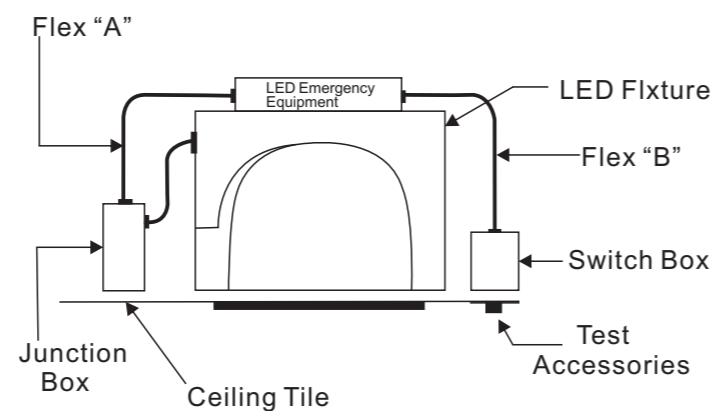

5. LABELS

Attach the appropriate labels adjacent to the Test Switch and Charge Indicator. Annotate Replacement Label for LED array type and wattage. The Caution and the Relamping labels must be on the fixture in a readily visible location to anyone attempting to service the fixture.

6. WIRING THE A.C. INPUT

A. The LED Emergency Equipment and A.C. driver must be on the same branch circuit.

B. When the LED Emergency Equipment is used with a switched fixture, the A.C. input to the LED Emergency Equipment must be connected ahead of the fixture switch. Refer to Illustration 2 for switched and unswitched fixture wiring diagrams.

Illustration 2: Switched Fixture

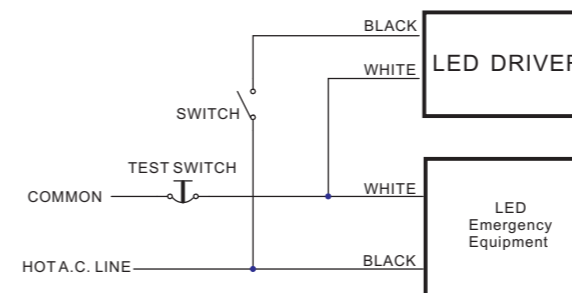

Unswitched Fixture

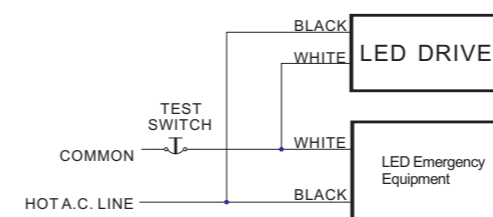

7. COMPLETING INSTALLATION

When the installation is complete, switch the A.C. power on and join the LED Emergency Equipment unit connector.

OPERATION

Normal Mode- A.C. power is present. The A.C. driver operates the LED load as intended. The LED Emergency Equipment is in the standby charging mode. The Charge Indicator will be lit providing a visual indication that the battery is being charged.

Emergency Mode- The A.C. power fails. The LED Emergency Equipment senses the A.C. power failure and automatically switches to the Emergency Mode. One or multiple LED are illuminated, for a minimum of 90 minutes. When the A.C. power is restored, the LED Emergency Equipment switches the system back to the Normal Mode and resumes battery charging. See page 1 of the Instruction Manual.

Instruction Manual LED Emergency Equipment

TESTING & MAINTENANCE

Pressing the Test Switch turns off the light on the Charge Indicator and forces the unit into emergency mode, interrupting power to the designated A.C. driver. The LED load is now being lit by the LED Emergency Equipment unit. After releasing the Test Switch, the fixture returns to normal operation after a momentary delay. To simulate a "BLACK OUT" use the circuit breaker to turn off A.C. power.

Initial Testing- Allow the unit to charge approximately 1 hour, then conduct a short discharge test. Allow a 24 hour charge before conducting a one hour test.

The LED Emergency Equipment is a maintenance free unit, however, periodic inspection and testing is required. NFPA 101, Life Safety Code, outlines the following schedule:

Monthly- Insure that the Charge Indicator light is illuminated. Conduct a 30 second discharge test by depressing the Test Switch. At least one LED should operate at reduced output.

Annually- Insure that the Charge Indicator is illuminated. Conduct a full 90 minute discharge test. The unit should operate as intended for the duration of the test.

Written records of testing shall be kept by the owner for inspection by the authority having jurisdiction.

TYPICAL WIRING DIAGRAM

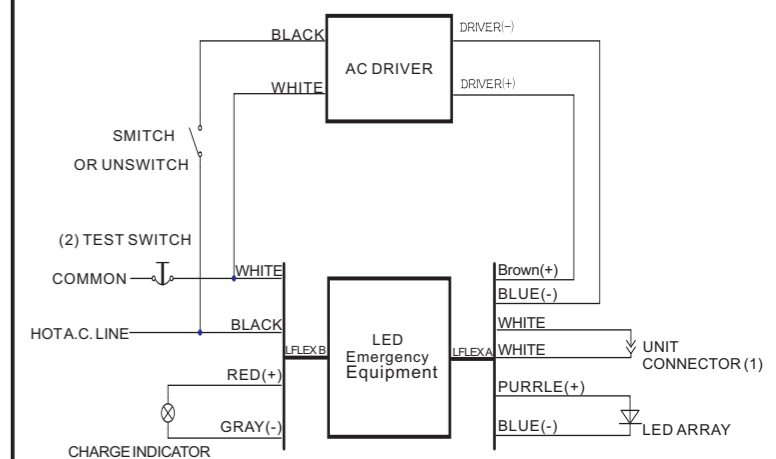

(1) DO NOT MATE CONNECTOR UNTIL INSTALLATION IS COMPLETE AND AC POWER IS SUPPLIED.

(2) TEST ACCESSORY LEADS-OBSERVE PROPER POLARITY WIRING.