

Product Description

The Design series canopy is available for surface or pendant mounting configurations with an optical distribution designed specifically to replace HID lighting systems up to 100w. Typical lighting applications include retail centers, industrial parks, schools and universities, public transit and airports, office buildings and medical facilities. Mounting heights of 8 to 14 feet can be achieved.

> Quick Ship - In Stock, Ready to Ship

Project:		Type:
Location:		
Prepared By:		Date:
Comments:		

Performance Summary

- Samsung LEDs with high efficacy >145 Lm/W
- USA assembled product with quick warranty support
- Standard design with modern components, excellent choice for retrofitting
- Patented heat dissipation design for optimum efficiency
- National listing lab tested to IES standards with Type V optic
- High lumen maintenance exceeds DOE requirements
- Solid State with high-shock and vibration resistance
- Aluminum LED boards with copper tracings for best thermal management
- LED array manufactured using a state-of-the-art SMT machine
- Clear polycarbonate prismatic lens
- A360 extruded ingot die-cast housing and ballast box
- DuPont textured architectural bronze powdercoat finish
- Chromate conversion coating for long lasting appearance
- Custom housing colors available upon request
- 1/2" coin plugs with o-rings for conduit and photocell on two sides and back
- Mounts directly over a 4" recessed outlet box or 1/2" surface conduit
- Rust resistant stainless steel hardware with durable nickel-plating
- Fin heatsinks for best heat dissipation and long life
- High CRI - RA>84 enhances original colors
- 1-10V dimmable driver with surge protection and battery backup option
- Fast turn on with no warm up or cold start issues
- Contains no mercury, lead, infrared or UV radiation and cool to the touch
- Operating temperature: -40 to 50 degrees celsius
- Samsung chip platform with completed 6,000 hour LM-80 test
- 187,000 hour LED life @ L70 tested at 25 degrees celsius
- Certifications: CE, RoHS, CSA - IP65 outdoor rated
- 5 year system warranty

DESIGN SM SERIES

Small Prismatic Lens with Multiple Mounting Options
LED Dimmable Luminaire

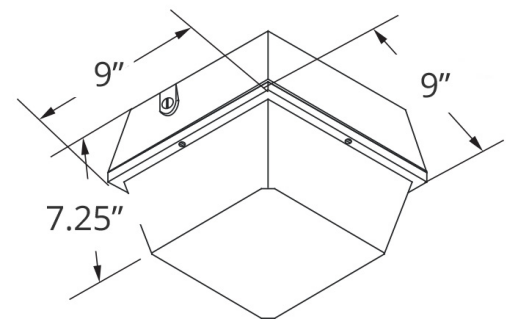

Models:

- WDVN30QFR: 23W - 3344 Lm

Ordering Information:				Part Number:		
*Adder Applies		**Adder Applies. Extended Lead Time May Apply.		Ordering Example: WDVN30QFR-50-S5C-V27-BZ-ND		
Family	CCT	Optic	Voltage	Finish	Dimming	Accessories*
WDVN30QFR	30 - 3000K** 40 - 4000K** 50 - 5000K	S5C - Type V Short 115 Degree	V27 - 120-277V	BZ - Bronze CS - Custom*	ND - Non Dim DM - 1-10V Dim	SF - Single Fuse DF - Double Fuse SP - 20kA Surge Protection 120-277VAC EM - Emergency Driver Provides 90 Minutes of Backup Power PC1 - 120V Photocell PC2 - 240-277V Photocell CP - Clear Polycarbonate Replacement Lens



Vivid Leds, Inc.
PO BOX 9
Sellersburg, IN 47172
800-974-3570
www.vividleds.us

Dimensions, specifications, and product pictures are subject to change without notice.

C5