

Product Description

The Design series is garage luminaire with optional integral sensor is available with an optical distribution designed to replace HID lighting systems up to 175w. Typical parking garage applications include retail centers, industrial parks, schools and universities, public transit and airports, office buildings and medical facilities. Mounting heights of 8 to 14 feet can be achieved.

> Quick Ship - In Stock, Ready to Ship

Project:		Type:
Location:		
Prepared By:		Date:
Comments:		

Performance Summary

- Samsung LEDs with high efficacy >130 Lm/W
- USA assembled product with quick warranty support
- Commercial white or 590nm amber for turtle lighting
- Low profile design with a modern appearance
- Patented heat dissipation design for optimum efficiency
- National listing lab tested to IES standards with Type V optic
- High lumen maintenance exceeds DOE requirements
- Solid State with high-shock and vibration resistance
- Aluminum LED boards with copper tracings for best thermal management
- LED array manufactured using a state-of-the-art SMT machine
- Molded UV-resistant acrylic optical lens designed for garage lighting applications
- A360 extruded ingot die-cast housing and ballast box
- DuPont textured architectural bronze powdercoat finish
- Chromate conversion coating for long lasting appearance
- Custom housing colors available upon request
- Easy-Hang bracket fits standard 4" electrical box, allowing one person installation
- Built-in sensor housing with polycarbonate cover for microwave sensor
- Knockouts for external mount sensor and conduit entry
- Rust resistant stainless steel hardware with durable nickel-plating
- Fin heatsinks for best heat dissipation and long life
- High CRI - RA>80 enhances original colors
- 1-10V dimmable driver with surge protection and battery backup option
- Fast turn on with no warm up or cold start issues
- Contains no mercury, lead, infrared or UV radiation and cool to the touch
- Operating temperature: -40 to 50 degrees celsius
- Samsung chip platform with completed 6,000 hour LM-80 test
- 147,000 hour LED life @ L70 tested at 105 degrees celsius
- Certifications: CE, RoHS, CSA - IP65 outdoor rated
- 5 year system warranty

DESIGN FT SERIES

Low Profile with One Person Installation with Easy Hang Bracket
LED Dimmable Luminaire

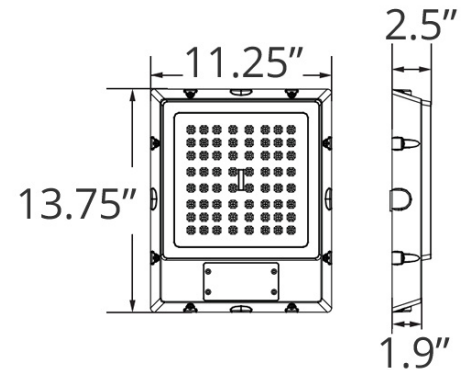

Models:

- WDVN55FR: 48W - 6444 Lm

Available in Amber 590nm

Ordering Information:				Part Number:		
*Adder Applies		**Adder Applies. Exstended Lead Time May Apply.		Ordering Example: WDVN55FR-50-S5C-V27-BZ-ND		
Family	CCT	Optic	Voltage	Finish	Dimming	Accessories*
WDVN55FR	30 - 3000K** 40 - 4000K** 50 - 5000K 1 - 590nm*	S5C - Type V Short 115 Degree	V27 - 120-277V	BZ - Bronze WT - White CS - Custom*	ND - Non Dim DM - 1-10V Dim	SF - Single Fuse DF - Double Fuse SP - 20kA Surge Protection 120-277VAC EM - Emergency Driver Provides 90 Minutes of Backup Power MS - Internal Microwave Motion Sensor QM - Hinged Quick Mount Bracket 3/4" NPS Downrod



Vivid Leds, Inc.
PO BOX 9
Sellersburg, IN 47172
800-974-3570
www.vividleds.us

Dimensions, specifications, and product pictures are subject to change without notice.

C10